

<b>Issued By:</b>	<b>Materials Logistics Department</b>	<b>MS 8314-04</b>	
		Issue Date 11-2020	Replaces 05-2005
<b>Subject:</b>	<b>Saudi Aramco Packing Specifications</b>		1 of 4 Pages

## Part II

### WOODEN CRATE PACKING SPECIFICATION

**REQUIREMENTS:** These requirements are in addition to any that may be in the material descriptions or other Saudi Aramco specifications, including Saudi Aramco Packing Specification 8314-02, which should be used in combination with this specification. Deviation from these requirements is not allowed without the Buyer's prior written approval.

1. **Crate Design:** The attached figure shows suggested designs which fulfill Saudi Aramco's requirements. Other crate designs which offer equal, or better, protection may be used if the designs comply with international standards (e.g., BS, DIN, JIS) or with the Buyer's written approval.
  
2. **Construction:**
  - 2.1 Lumber must be new, sound, and well-seasoned with a moisture content between 12 and 20%. Knots must be sound and not in excess of 1/3 of the width of the board and must not cause any nailing interference. Where possible, nails should be driven into side grain of lumber.  
  
Lumber sizes indicated are nominal and must be considered as a minimum.  
  
Where a range is indicated, the lumber dimensions will depend on the weight and type of materials to be packed. Vendor is to ensure that the lumber dimensions selected are adequate for the weight and type of materials.
  - 2.2 Fasteners must be of adequate length and quantity and must be of the coated type; e.g., cement, resin, galvanized, or chemically etched. Staples are not permitted.
  - 2.3 Metal strapping must be unannealed steel applied with a stretching tool and secured with joints as strong as the strapping. No sharp edges are to be left exposed.
  - 2.4 Additional members may be required to distribute concentrated loads over the area of the crate base.
  - 2.5 In general, crates should be constructed in such a manner that the openings between the boards are equal to, or less than, the width of the boards.

3. **Layout:**

- 3.1 Articles must be nested or packed firmly in minimal space. Unnecessary free space within the crate must be avoided to reduce shipping costs.
- 3.2 Component parts, attachments, etc., especially if fragile or susceptible to atmospheric damage, must be boxed separately and braced within the crate containing the main unit.
- 3.3 All items must be secured to the base of the crate. Where bolts are practical, heavy items must be bolted to the skids through the crate base or to load-bearing members which distribute the load to the skids.

4. **Dimensions:** If dimensions exceed 12-m length, 2.5-m width, or 3.45-m height, the Buyer must be notified.

Copyright © 2020 Saudi Aramco. All rights reserved

**CRATE TYPE 1**

For net weights up to 250 kg (550 lb)

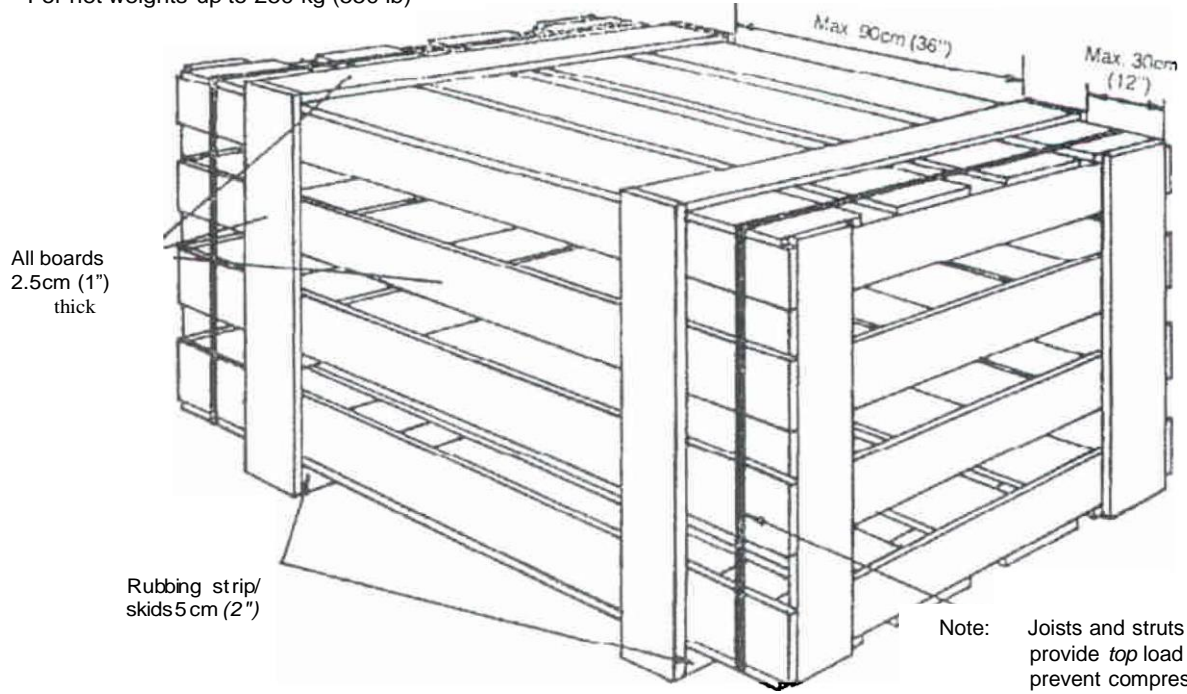

**CRATE TYPE 2**

For net weights 250-500 kg (550-1,100 lb)

3-WAY CORNER detail

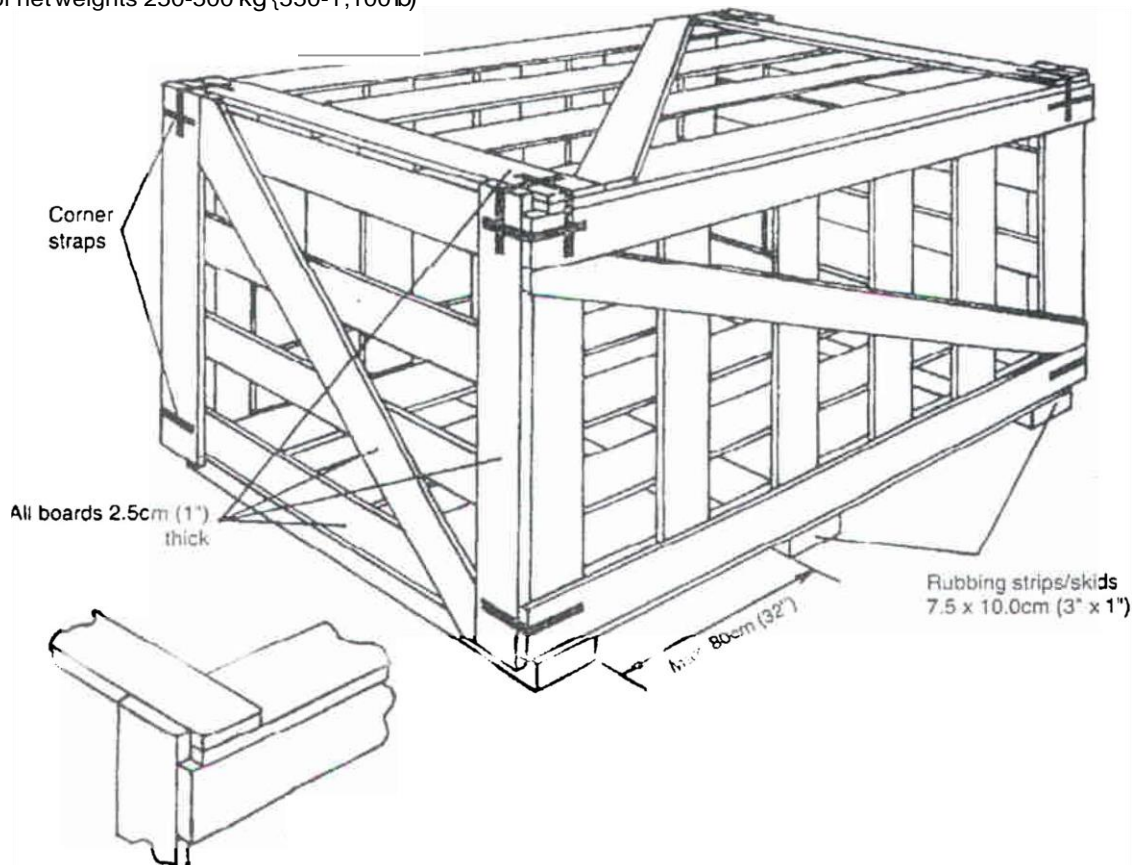

### CRATETYPE3

For net weights 500-5,000 kg (1,100-11,000 lb)

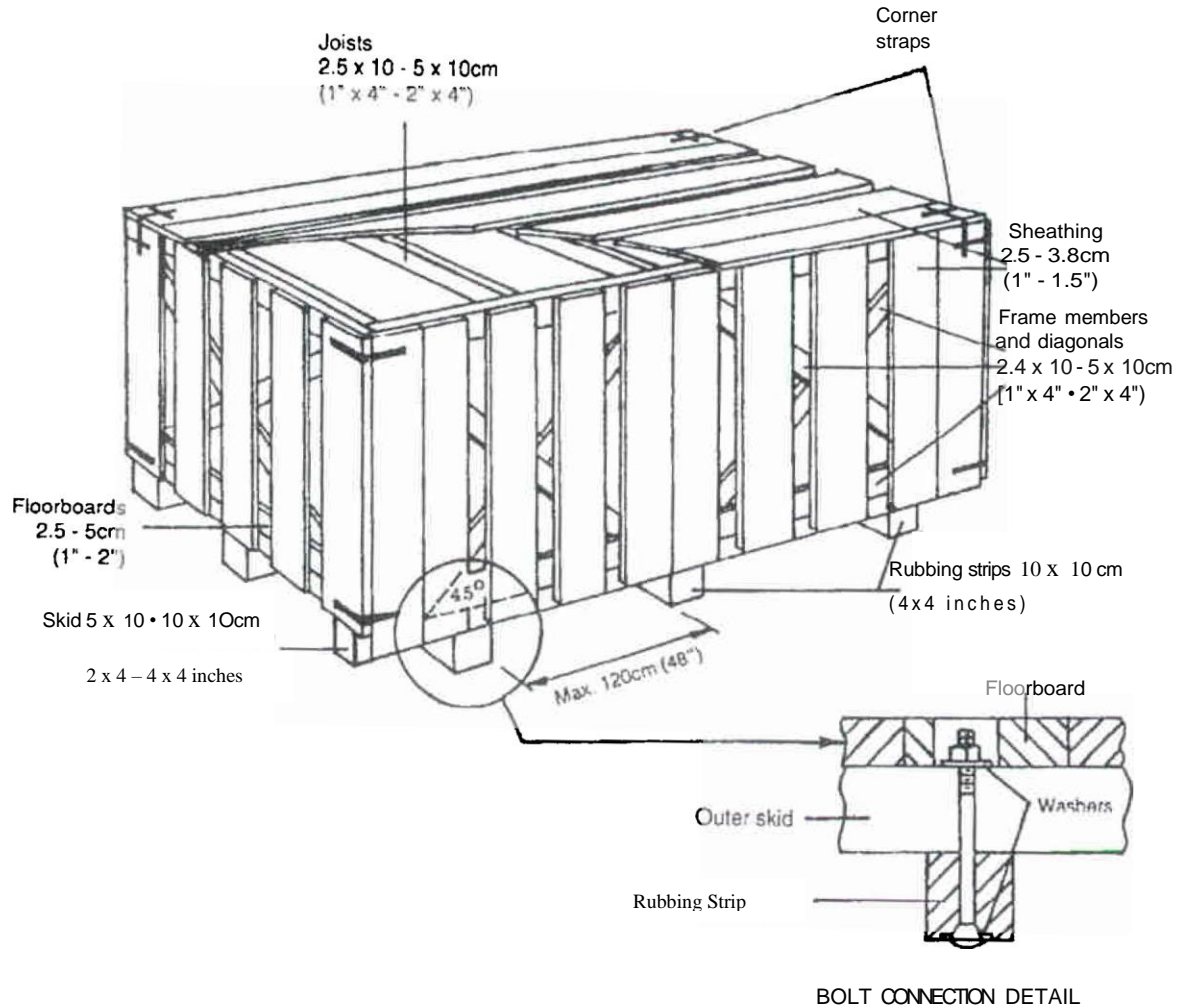

Notes: 1. For net weights over 5,000 kg (11,000 lb), crate design is to be certified and shared with Saudi Aramco

2. joists and struts of adequate size and quantity must be applied to provide top load support and to prevent Compression by slings.