

		MS 8444-09	
Issued By:	Materials Logistics Department	Issue Date	Replaces
		11-2020	05-2005
Subject:	Saudi Aramco Packing Specifications		1 of 4 pages

Additional Packing, Packaging, and/or Marking Requirements

1. **MATERIALS:** Pipes
- 2 **RANGE OF MATERIALS:** Saudi Aramco Materials covered in materials services group 015000, for the above materials description, and direct charge purchase items of the same kind.
3. **REQUIREMENTS:** These requirements are in addition to those in the material master descriptions, and Saudi Aramco Standard Packing Specifications and apply only to the materials indicated. Deviation from these requirements is not allowed without the Buyer's prior written approval.

- 3.1 Steel line pipe within the materials groups listed in paragraph 2 and similar pipe purchased direct charge must be provided with protectors. This specification is a statement of Saudi Aramco's minimum requirements. For alternative protectors, see paragraph 3.3.

Exception: protectors are not required for pipe purchased from in- Kingdom pipe manufacturers and for immediate installation.

- 3.2 Recessed plastic caps or protectors be used follows. (Pipe diameter ranges are nominal.)

- 3.2.1 Pipe smaller than 153 mm (6 in): Snug-fitting plastic caps or plugs as described in diagrams A1 and A2.

Diagram A1 (cap): The thickness (T) of the cap must be minimum 3 mm. The length (L) must be minimum 0.5 x nominal pipe diameter (D).

Diagram A2 (plug): The thickness (T) of the plug flange must be minimum 3 mm.

The plug flange diameter (D) must be:

Maximum D= OD

Minimum D = ID + 2(0.9 x WT)

OD = outside diameter of pipe

ID = inside diameter of pipe

WT = wall thickness of pipe

3.2.2 Pipe 153 mm (6 in) up to and including 305 mm (12 in): Recessed plastic caps or plastic ring protectors as described in diagrams A1 and A2: Both types must be snug-fitting to both the outside and the inside of the pipe. The thickness of the material protecting the bevel must be minimum 5 mm. The outside length (L1) must be minimum 80 mm. The depth of the recessed cap (L2) must be minimum 50 mm. The inside length (L3) of the ring protector must be minimum 20 mm.

3.2.3 Pipe larger than 305 mm (12 in): Metal end protectors of the recessed expanding type (wedge or screw), fabricated from light-gauge steel as described in diagram C: The inner height of the bevel guard (H) must be between 0.5 and 0.9 x WT (wall thickness of pipe). The length of the protector must be minimum 40 mm.

3.3 The attached diagrams describe designs preferred by Saudi Aramco.

3.3.1 The plastic protectors described in diagrams A and B may be replaced with protectors of a different design or material (polyethylene/steel) that provide equal or better protection to the bevel. Closed, flat-end caps that inhibit the use of pipe hooks are not permitted on pipe 153 mm (6 in) and over.

3.3.2 Deviation from the steel protector described in diagram C on pipe over 305 mm (12 in) requires the Buyer's written approval.

3.4 Protectors lost during handling up to the delivery point (according to agreement in the purchase order) must be replaced. Pipe with inadequate, missing, or damaged protectors may be rejected for shipment.

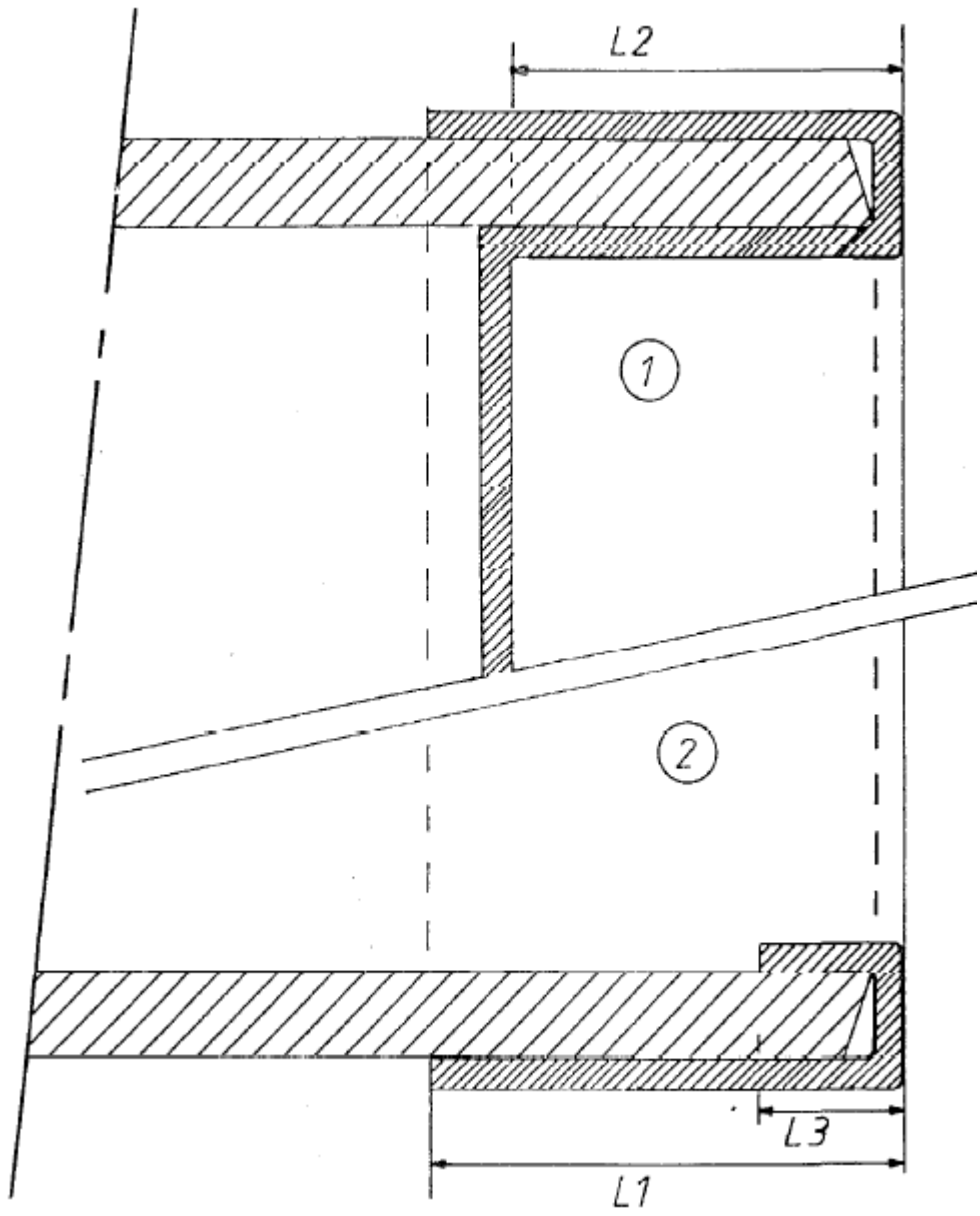

DIAGRAM A

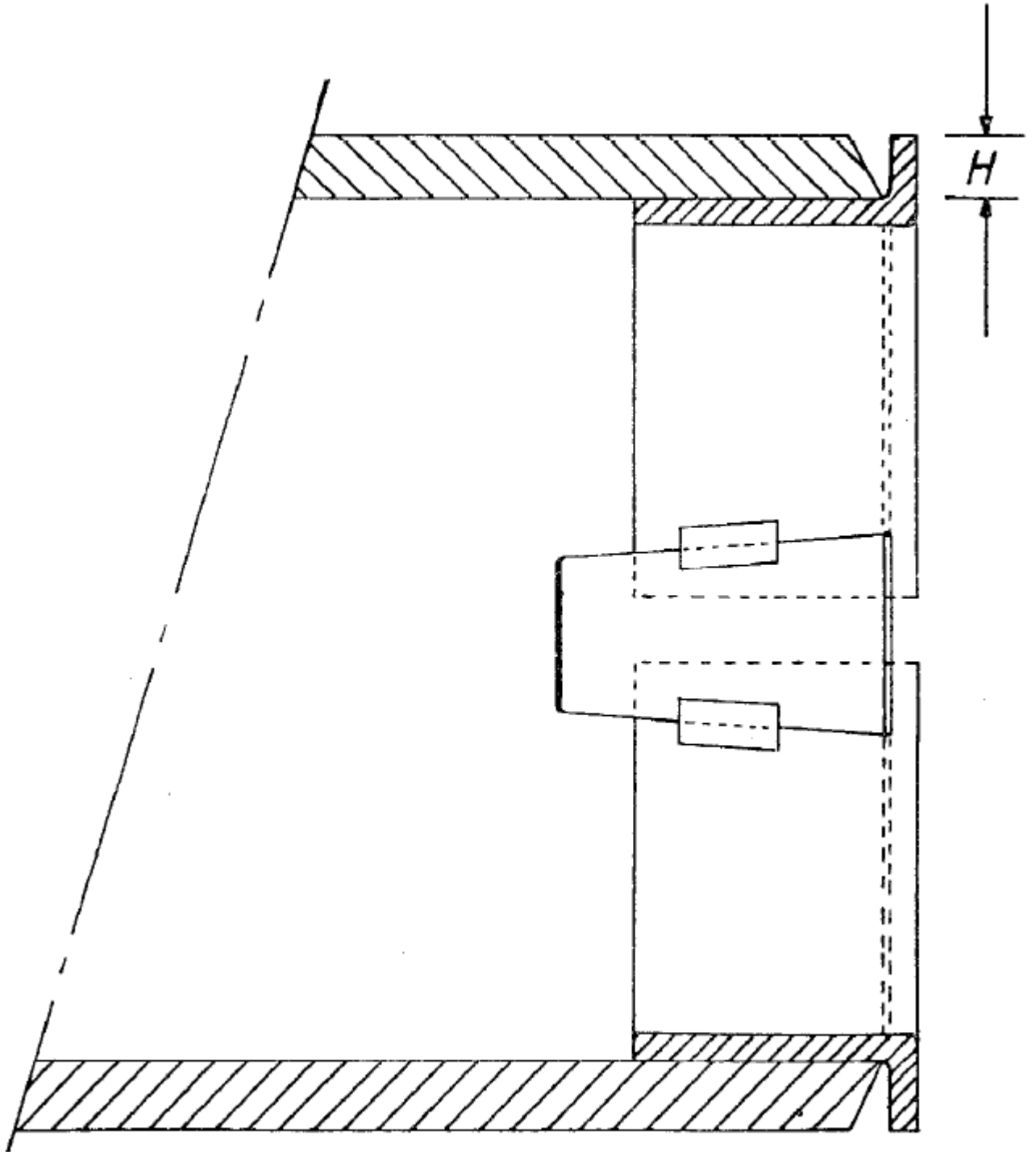

DIAGRAM B